

# FABLON

## HEAVY DUTY BELTING

### THE "LONGHORN"

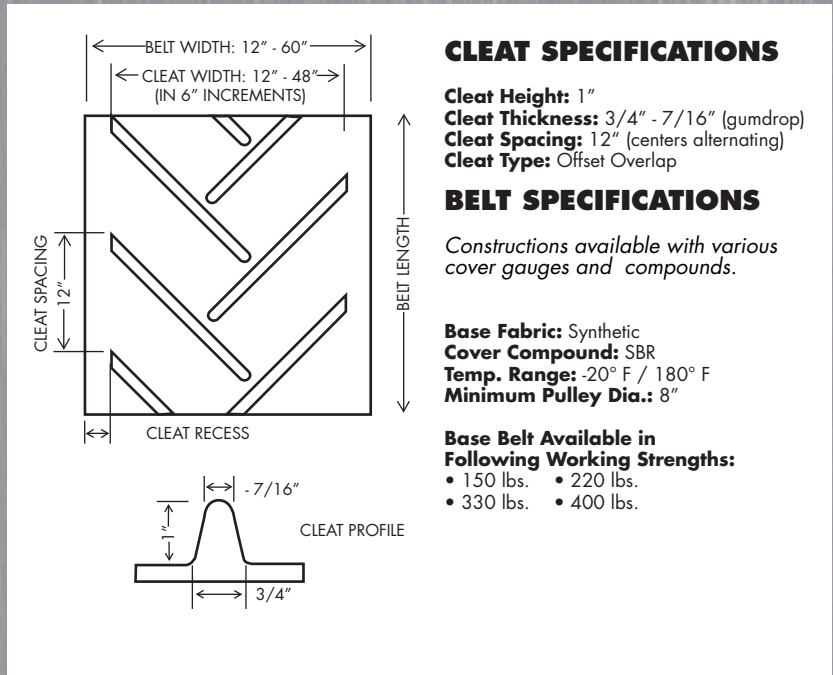

Like the **Fablon Bighorn**, **Bullhorn** and **Fablift**, the **Longhorn** offers a new angle on loading belts.

This unique cleat design provides smooth, reliable product delivery in demanding incline applications. Used for large, abrasive or heavy loads, this heavy-duty loading belt offers over four to six times the cleat wearing surface of conventional slab-cleated belting. A taller, thicker cleat profile provides more "bite" and wearing surface than all other competitive brands. Its overlapping cleat design allows the belt to ride smoothly over return idlers. Variable cleat widths let you order belting to match your equipment.

#### Choosing the Right Belt

**Longhorn** belting offers a taller, aggressive cleat design that allows for easy handling of large, heavy or wet materials like sugar beets and recycling. The design maintains constant contact with return idlers and can be troughed as necessary.

#### Integrally Molded Cleats

Integral molding ensures that the cleats become homogenous with the cover of the belt.

#### Belt Ordering Information

When ordering or requesting an estimate for your belting, please specify: (1) the exact **belt length** from end to end, (2) the overall **belt width**, (3) the desired **cleat width**, (4) the desired **cleat recess**, (5) the **pulley diameter**, and (6) the type of **end splicing** desired: either open-end (no splice), hot vulcanized splice, laced, or prepared ends.

# MORE FABLON FABRICATIONS



**THE BIGHORN** belt offers a 3/4" high x 3/4" thick rounded at the top cleat on 9" centers. This belt is ideal for smooth delivery of loads requiring a cleated belt for elevation of product up steep inclines. The Bighorn maintains constant contact with return idlers and can be troughed on conventional troughing idlers.



**THE BULLHORN** belt offers a tight, low-profile cleat design for smooth delivery of loads such as planed asphalt and wood chips. Used for large, abrasive or heavy loads, the Bullhorn provides four to eight times the cleat surface of conventional slab-cleated belting.



**THE FABLIFT** has a unique cleat design that provides reliable product delivery in demanding incline applications. This belt maintains constant contact with return idlers and can be troughed on conventional troughing idlers.



**THE FABTOUGH** sweeper belt is designed for longer performance and extended service life, versus the standard replacement belts currently available in the market. Engineered for severe environments, FabTough belting will keep sweepers up and running at peak performance.

Maine Industrial Plastics and Rubber Corporation  
21 Teague Street - PO Box 381 - Newcastle, ME 04553  
Phone: (207) 563-5532 Email: HGL@TIDEWATER.NET FAX: (207) 563-8457